

YALÇIN GOLD BATTERY

6 OPzS 600 (2V600AH)

Specification

Nominal Voltage	2V	
Capacity(10HR)	600.0AH (1.8V/cell,20 °C)	
Dimension	Length	145±2mm (5.71 inches)
	Width	206±3mm (8.11 inches)
	Container Height	646±3mm (25.4 inches)
	Total Height (with Terminal)	701±3mm (27.6 inches)
	Without Electrolyte	33.4 kg (73.6lbs)
Approx Weight	With Electrolyte	45.4 kg (100.1lbs)
	Container Material	SAN transparent container
Rated Capacity	600.0 AH/60.0A	(10hr, 1.80V/cell,20°C/68°F)
	533.0 AH/106.6A	(5hr, 1.75V/cell,20°C/68°F)
	462.6 AH/154.2A	(3hr, 1.75V/cell,20°C/68°F)
	342.6 AH/342.6A	(1hr, 1.60V/cell,20°C/68°F)
Max. Discharge Current	4800A (5s)	
Internal Resistance	Approx 0.45mΩ	
Operating Temp.Range	Discharge	-15~55°C (5~131°F)
	Charge	0~45°C (32~113°F)
	Storage	-15~45°C (5~113°F)
Type and number of poles	M8/2	
Charging	Floating voltage: 2.23V~2.25V at 20 °C(68°F)Temp.	
	Boost charge: 2.30V~2.40V at 20 °C(68°F)Temp.	
	Charging current(max.): 0.1CA	
	Temp.Coefficient -3mV/°C	
	Capacity affected by Temperature	40°C (104°F)
	25°C (77°F)	100%
	0°C (32°F)	86%
Self Discharge (4% per month)	Gold OPzS batteries may be stored for up to 6 months at 20°C(68°F) and then a freshening charge is required. For higher temperatures the time interval will be shorter.	



Applications

- ◆ Telecommunications.
- ◆ Radio and cellular telephone relay stations.
- ◆ Emergency lighting systems.
- ◆ Power stations, Conventional power stations,
- ◆ Alternative power (solawind).
- ◆ Large UPS and computer back-up.
- ◆ Railway signalling.
- ◆ Maritime standby power on ships and ashore.
- ◆ Standby power
- ◆ Buoy lighting.
- ◆ Long service life, designed life 15-20 years.

Constant Current Discharge (Amperes) at 20 °C (68°F)

F.V/Time	30mi n	45mi n	1h	1.5h	2h	3h	4h	5h	6h	8h	10h	20h
1.60V/cell	454.8	395.2	342.6	270.0	223.2	166.8	134.1	113.4	98.2	77.7	64.2	34.8
1.65V/cell	427.2	380.0	331.2	263.2	218.1	164.0	132.2	111.9	96.8	76.7	63.4	34.5
1.70V/cell	405.6	358.4	318.6	254.8	213.0	159.2	129.2	109.5	95.0	75.4	62.4	34.0
1.75V/cell	380.4	341.6	302.4	242.8	204.0	154.2	125.3	106.6	92.7	74.1	61.3	33.4
1.80V/cell	338.4	308.0	278.4	227.6	191.7	146.4	119.9	102.2	89.3	72.1	60.0	32.8
1.85V/cell	270.0	255.2	238.2	202.4	174.0	134.0	110.9	95.8	84.1	68.5	57.4	31.5

Constant Power Discharge (Watts) at 20 °C (68°F)

F.V/Time	30mi n	45mi n	1h	1.5h	2h	3h	4h	5h	6h	8h	10h	20h
1.60V/cell	776.3	691.6	608.3	485.4	405.9	305.5	247.8	211.0	183.8	146.1	121.2	66.0
1.65V/cell	745.1	672.9	592.9	475.5	398.6	301.9	245.4	209.2	182.2	145.0	120.3	65.7
1.70V/cell	717.1	641.3	574.7	463.4	391.0	294.5	240.6	205.5	179.3	143.0	118.7	65.0
1.75V/cell	683.9	617.7	550.6	444.8	377.2	287.0	234.5	201.0	175.6	141.1	117.3	64.2
1.80V/cell	616.6	565.5	513.4	421.7	357.6	274.6	225.9	193.6	170.2	138.0	115.4	63.3
1.85V/cell	500.3	475.3	445.7	380.2	328.2	254.0	211.1	183.0	161.5	132.2	111.3	61.4

Specifications subject to change without notice.



Dimensions

Terminal

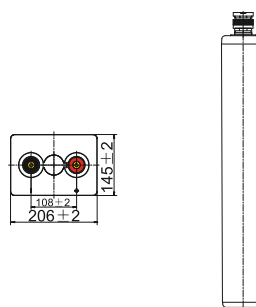
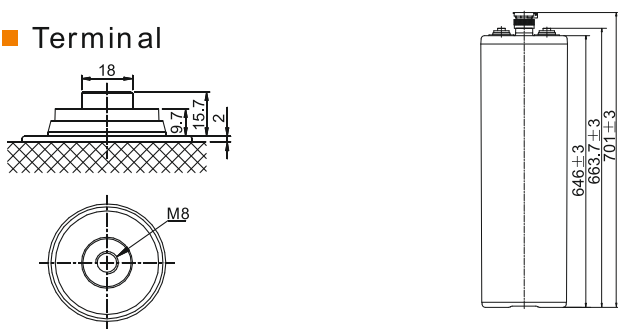

Discharge Characteristics

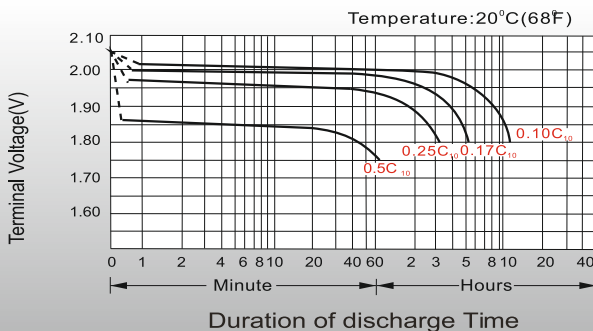

Charge voltage Vs ambient temperature curve

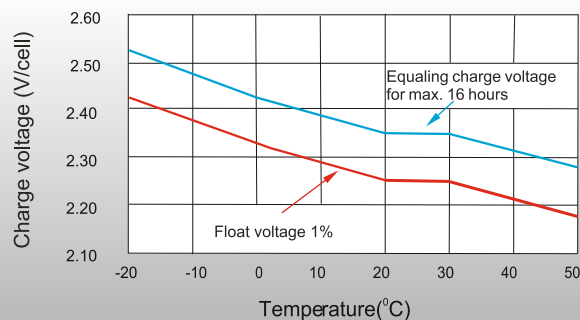

Discharge capacity Vs Ambient temperature curve (I10A)

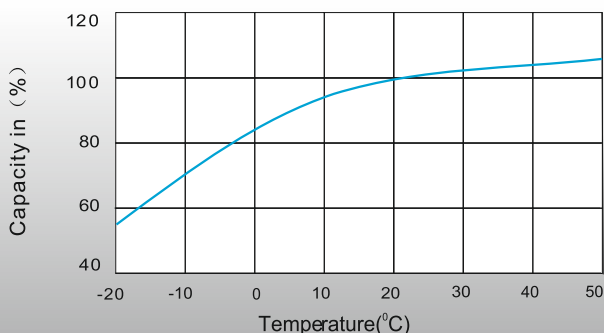

Relation curves of service life and ambient temperature

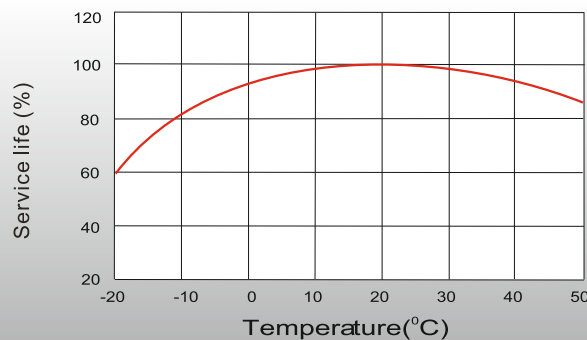

Self Discharge Characteristics

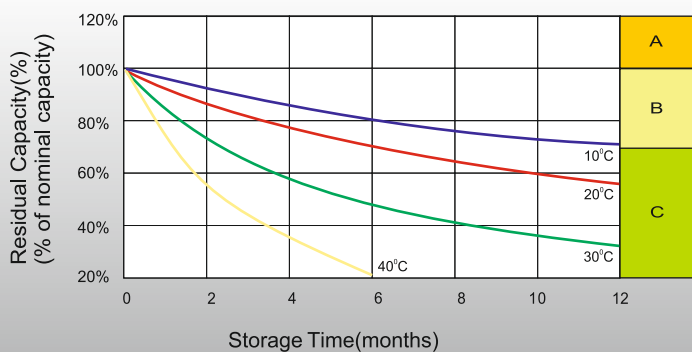

- A** No supplementary charge required (Carry out supplementary charge before use if 100% capacity is required.)
- B** Supplementary charge required before use. Optimal charging way as below :
 1. Charge for above 3 days at limited current 0.1CA and constant voltage 2.25V/cell.
 2. Charge for above 20 hours at limited current 0.1CA and constant voltage 2.45V/cell.
 3. Charge for 8~10 hours at limited current 0.05CA .
- C** Supplementary charge may often fail to recover the capacity .
The battery should never be left standing till this is reached.

Merkez

100. Yıl Bulvarı 1232. Sokak
(Eski 40. Sokak) No: 65
Ostim / ANKARA

Tel&Fax

T. (0.312) 354 16 45
(0.312) 385 55 60
F. (0.312) 354 07 97

Servis

100. Yıl Bulvarı 1234. Sokak
(Eski 57. Sokak) No: 91
Ostim / ANKARA

Fabrika

Kırıkkale OSB Kızılırmak Caddesi
4. Sokak No: 6
Yahşihan / KIRIKKALE